

ECO NO.	DATE	REV.	REVISION RECORD	AUTH.	SR. NO.
1400	1/23	A	WIRE FROM COIL TO NEG. SIDE OF BALLAST RESISTOR WAS #14 PURPLE	WRM	
1732	5/7	B	WIRE FROM COIL PLUG TO CHOKE SOL. NOW RUNS FROM START SW. TO CHoke SOL. TO START SW. TO START SW.	WRM	
1810	1/17	C	WIRE FROM COIL SOL. TO START SW. NOW RUNS FROM COIL SOL. TO START SW. TO START SW. TO START SW.	WRM	
2679	1/14	D	ADDED OVERSPEED SWITCH DETAIL. ADDED NEW OVERSPEED SWITCH. REWIND ON 2. A.D.	WRM	
2722	4/14	E	RE WIRE OVERSPEED SW. #14 TO TBI-4 NOW T4 TO TBI-2 AND UPDATED REMOTE PANEL CONNECTION	WRM	
3084	10/27	F	GROG. EXHOS. REMOVED. EXHAUST LABEL ADDED.	WRM	
3110	1/21	G	ADD GROUND WIRE FROM TBI-5	BRN	
4703	8/1	H	WIRE RED/PUR WAS CHANGED FROM YEL/RED TO MATCH ENGINE HARNESS. ADDED NOTE.	TSM	

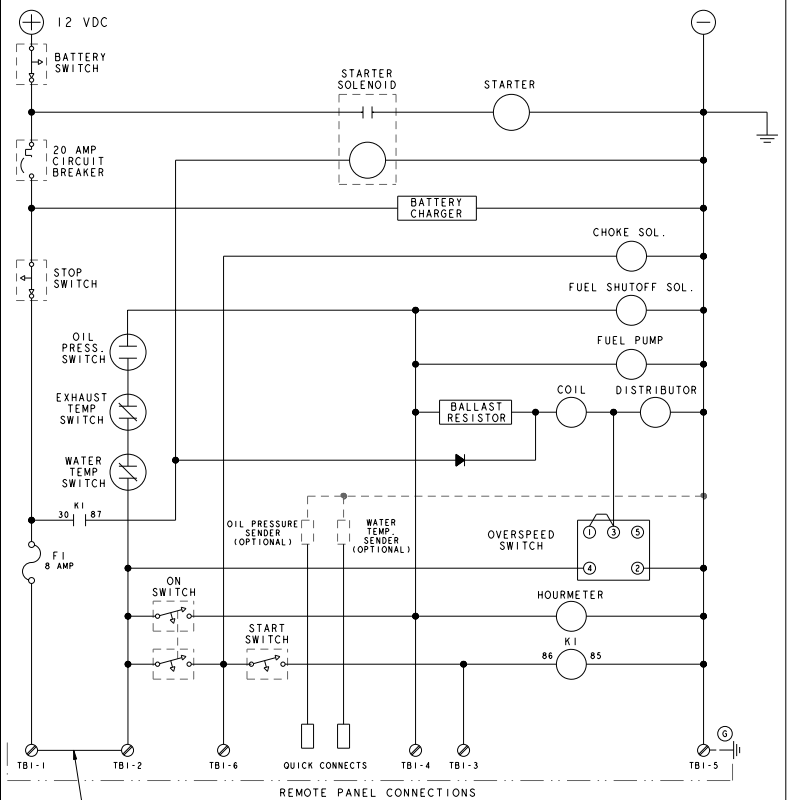

REMOVE JUMPER BETWEEN TBI-1 AND TBI-2 WHEN USING REMOTE PANEL.

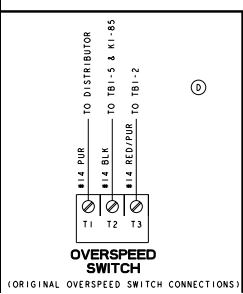

NOTE: I. REFERENCE PANEL, BOX AND HARNESS P/N 37995.

TOLERANCES (UNLESS OTHERWISE NOTED)		WESTERBEKE CORPORATION WILSON, MA. 02322	
INCHES	MILLIMETERS	DATE	WIRING DIAGRAM, 4.5 AND 7.0 KW - BCG GASOLINE GENSET
FRAC.	DEC.	BY	DATE
1/16	0.015	APP'D BY	DATE
1/32	0.005	DATE	3/20/00
3/16	0.020	INTERNAL	
1/2	0.050	DIMENSIONS	
1	0.125	INCHES	
		MILLIMETERS	
		SCALE	SIZE
		DRW. NO.	38028
		REV.	H